

# **CM**<sup>®</sup>

# **SERIES 653**<sup>™</sup>

## **RATCHET LEVER HOIST**

MODEL 653-A

---

## **THE ADVANTAGES OF THE SHORTER HANDLE**

As part of our commitment to bring best-in-class products to market, we are always innovating and improving on existing CM products. Our popular CM Series 653 ratchet lever hoist has been redesigned to be lighter and more compact for ease of use and even lower headroom applications. With a shorter handle length and optimized weight, the CM Series 653-A 3/4 and 1-1/2 ton models are among the easiest hoists to operate, outmatching competitors in usability and reliability.

### **EXPERIENCE A MORE COMPACT, MODERN DESIGN.**

A shorter handle for more effortless operation.

### **LESS WEIGHT TO TRANSPORT**

Lighter and more compact than the original CM 653 hoist, the 653-A is one of the easiest hoists to carry and operate.

### **MAKE THE FULL ROTATION**

The 360° rotating handle allows for near effortless operation without the worry of obstructions.

## **BENEFITS & FEATURES**

### **CAPACITIES & LIFT**

3/4, 1, 1-1/2, and 2 ton capacities (new shorter handle).  
3 & 6 ton capacities (standard handle).  
Metric Rated. Standard Lift up to 20 feet.

### **COMPACT & PORTABLE DESIGN**

Take this rugged hoist anywhere. Easily transported and rigged in the smallest work spaces.

### **FREE CHAINING**

Single-handed free chaining feature allows for quick take up and positioning of slack chain. Designed not to accidentally free chain while under load.

### **360° ROTATING HANDLE**

Full rotation of handle allows for versatile rigging options when working in confined spaces.

### **RUGGED DESIGN**

Impact resistant stamped steel frame and gear cover withstands repeated rigorous use.

### **BUILT TO LAST**

Zinc plated hardened steel chain provides strength and longer chain life, translating to less downtime and increased durability.

### **POSITIVE LOAD CONTROL**

Enclosed Weston type load brake stays clean and dry for positive load positioning.

### **LOAD CONTROL**

Double pawl design ensures that one pawl always will be engaged at all times for reliable load control.

### **SAFE & SECURE**

Standard heavy duty forged robust safety latches on hooks provide positive and secure load engagement.

### **CORROSION RESISTANT**

Standard powder coat finish for extra protection against corrosion when working in harsh environments.

### **NON-SLIP RUBBER HANDLE GRIP**

Comfortable rubber grip provides for extra protection against slippage.

### **MEETS ASME B30.21**

### **5 YEAR WARRANTY**

**FITS IN SMALL  
WORK AREAS.**

**LESS WEIGHT  
TO TRANSPORT.**

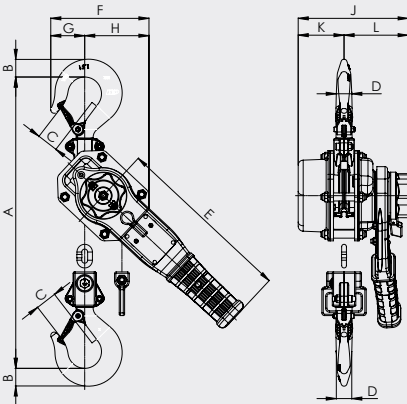

Capacity (tons)	Product Code	Standard Lift ft. (m)	Pull Force to Lift Rated Load lbf. (kgf)	Reeving	Weight lbs. (kg)	Dimensions in. (mm)										
						A (Min.)	B	C	D	E	F	G	H	J	K	L
3/4	5310A	5 (1.5)	51	1	13.8 (6.26)	11.78 (302)	0.78 (20)	1.05 (27)	0.7 (18)	10.41 (267)	4.72 (121)	1.56 (40)	3.16 (81)	5.62 (144)	2.07 (53)	3.55 (91)
3/4	5311A	10 (3)			16.05 (7.28)											
3/4	5312A	15 (4.5)			18.3 (8.3)											
3/4	5313A	20 (6)			20.55 (9.32)											
1	5328A	5 (1.5)	51	1	19.84 (9)	13.50 (343)	0.87 (22)	1.14 (29)	0.75 (19)	10.51 (267)	5.47 (139)	1.69 (43)	3.78 (96)	6.46 (164)	2.68 (68)	3.78 (96)
1-1/2	5315A	5 (1.5)	77	1	20.17 (9.15)	14.63 (375)	1.01 (26)	1.21 (31)	0.82 (21)	10.51 (267)	5.69 (146)	1.99 (51)	3.71 (95)	6.46 (164)	2.68 (68)	3.78 (96)
1-1/2	5316A	10 (3)			23.61 (10.71)											
1-1/2	5317A	15 (4.5)			27.12 (12.3)											
1-1/2	5318A	20 (6)			30.62 (13.89)											
2	5329A	5 (1.5)	58	1	35.27 (16)	16.10 (409)	1.18 (30)	1.38 (35)	0.87 (22)	14.80 (376)	6.81 (173)	1.97 (50)	4.84 (123)	7.60 (193)	3.27 (83)	4.33 (110)
3	5320A	5 (1.5)	87	1	37.17 (16.86)	17.52 (445)	1.64 (37)	1.57 (40)	1.10 (28)	14.80 (376)	7.09 (180)	2.24 (57)	4.84 (123)	7.60 (193)	3.27 (83)	4.33 (110)
3	5321A	10 (3)			44.29 (20.09)											
6	5330A	5 (1.5)	92	2	62.96 (28.56)	22.17 (563)	1.77 (45)	1.73 (44)	1.38 (35)	14.80 (376)	9.13 (232)	2.80 (71)	6.34 (161)	7.60 (193)	3.27 (83)	4.33 (110)
6	5331A	10 (3)			77.18 (35.01)											
6	5332A	15 (4.5)			91.4 (41.46)											
6	5333A	20 (6)			105.62 (47.91)											



## KNOW HOW...KNOW WHY

Columbus McKinnon is a global leader in providing expertise and training in the proper use and inspection of rigging and overhead lifting equipment. With a range of comprehensive programs and seminars conducted at venues throughout North America, as well as on site at private companies and industries, Columbus McKinnon courses include:

- Hoist Maintenance
- Load Securement
- Crane & Hoist Inspection
- Mobile Crane Operator
- Rigging
- Safe Hoisting
- Crane Operator Training
- Rigging Gear Inspection

Classes are available at our Niagara Training Center and the state-of-the-art Hoist & Rigging Training Center of Excellence in the Center for Occupational Health and Automobile Manufacturing (COHAM) lab at The Ohio State University. The COHAM lab is a hands-on learning center which allows attendees to understand how to properly use and inspect overhead lifting equipment. This leading edge training program is designed to increase workplace productivity and safety in a ergonomically friendly environment.

In addition to the strong knowledge base exemplified by comprehensive training programs, Columbus McKinnon is one of the only manufacturers supplying complete lifting systems to satisfy unique material handling requirements of users in a variety of environments. From jib cranes and hoists to chain slings, clamps, and related attachments; systems include products that are matched specifically to the lifting needs of the application. Products may also be modified in order to ensure that the proper system is in place for the job.

Whether your needs call for a single CM Series 653 ratchet lever hoist or a completely engineered system to outfit your production facility, Columbus McKinnon provides the products and expertise to keep your workforce productive and safe.



FAMILY OF BRANDS



PHONE (800) 888.0985 • FAX: (716) 689.5644 • [WWW.COLUMBUSMCKINNON.COM](http://WWW.COLUMBUSMCKINNON.COM)



**CM**<sup>®</sup>

**SERIES 653**<sup>™</sup>

RATCHET LEVER HOIST

MODEL 653-A

COLUMBUS MCKINNON CORPORATION