



# SHOPSTAR<sup>®</sup>

## ELECTRIC CHAIN HOIST

CAPACITIES	LIFT	SPEEDS	VOLTAGES
250 to 1000 lbs.	10 feet standard	6 to 40 feet/minute	1-phase & 3-phase available

The CM ShopStar electric chain hoist is built for rugged industrial and commercial use. This durable hoist features high H4 duty cycles and a compact design ideal for use at workstations and production lines. Standard overload device protects the hoist, operator and surrounding structure from damaging overloads.

**H4 DUTY CYCLE**  
300 motor starts per hour

**RUGGED & DURABLE**  
Thermally protected hoist motor. Cast aluminum alloy hoist frame with durable epoxy powder coat finish.

**LOW MAINTENANCE**  
Gear train lifetime lubricated with non-oxidizing grease. Totally enclosed hoist frame protects motor from environmental contamination.

**DUAL BRAKING SYSTEM**  
D.C. brake plus regenerative

**LONG CHAIN LIFE**  
Durable CM Hoist Alloy Load Chain. 10-pocket, oblique-lay lift wheel for longer chain wear.

**TRUE VERTICAL LIFT**

**NEMA 4 INDUSTRIAL-RATED CONTROL STATION**

**THE INDUSTRY'S BEST LIFETIME WARRANTY**

**OPTIONAL SWIVEL HOOK SUSPENSION**



Swivel Hook with latch

Swivel Hook with Latchlok<sup>®</sup> latch

### NOW AVAILABLE WITH OPTIONAL SWIVEL HOOK SUSPENSION

Providing versatility and flexibility, hook rotates 360° for easy attachment and positioning.



**CLEARANCE DIMENSIONS (IN.)**

Reeving	A	B	C	D
Single	11-1/16	3	2-15/16	3-7/8
Double	11-15/16	3-9/16	2-3/8	5-3/4

**SPECIFICATIONS**

Capacity (lbs.)	Product Code				Lift (ft.)	Lifting Speed (FPM)	Motor Hp	Reeving	Weight (lbs.)
	115-1-60 Contactor in Push Button Station	115-1-60 Contactor in Hoist	230-3-60	460-3-60					
250	2070	-	-	-	10	16	1/6	single	26
	-	2069	2071	2072	10	16	1/6	single	28
	-	-	2076	2077	10	24	1/6	single	28
	-	-	2081	2082	10	40	1/6	single	28
300	2000	-	-	-	10	16	1/6	single	26
	-	2047	2026	2029	10	16	1/6	single	28
	2002	-	-	-	15	16	1/6	single	28
	-	-	2027	2030	15	16	1/6	single	29
	2004	-	-	-	20	16	1/6	single	28
	-	-	2028	2031	20	16	1/6	single	30
	-	-	2086	2087	10	24	1/6	single	28
500	-	-	2074	2075	10	40	1/6	single	28
	2095	-	-	-	10	8	1/6	double	32
	-	2094	2096	2097	10	8	1/6	double	34
	2090	-	-	-	10	12	1/6	single	26
	-	2089	2091	2092	10	12	1/6	single	28
	-	-	2080	2084	10	16	1/6	single	28
	-	-	2101	2102	10	20	1/6	double	34
	-	-	2099	2100	10	24	1/6	single	28
600	2001	-	-	-	10	8	1/6	double	32
	-	2048	2035	2038	10	8	1/6	double	34
	2003	-	-	-	15	8	1/6	double	35
	-	-	2036	2039	15	8	1/6	double	37
	2005	-	-	-	20	8	1/6	double	37
	-	-	2037	2040	20	8	1/6	double	39
	-	-	2106	2107	10	12	1/6	double	34
	-	-	2105	2114	10	20	1/6	double	34
1000	2110	-	-	-	10	6	1/6	double	32
	-	2109	2111	2112	10	6	1/6	double	34
	-	-	2116	2117	10	8	1/6	double	32
	-	-	2119	2121	10	12	1/6	double	32

**CHAIN CONTAINERS (OPTIONAL)**

Product Code	Maximum Length of Lift (ft.)		Weight (lbs.)
	Single Reeved	Double Reeved	
2063	10	5	1.0
2064	20	10	1.4
2065	40	20	1.4
2066	80	40	1.4
2067	120	60	2.2

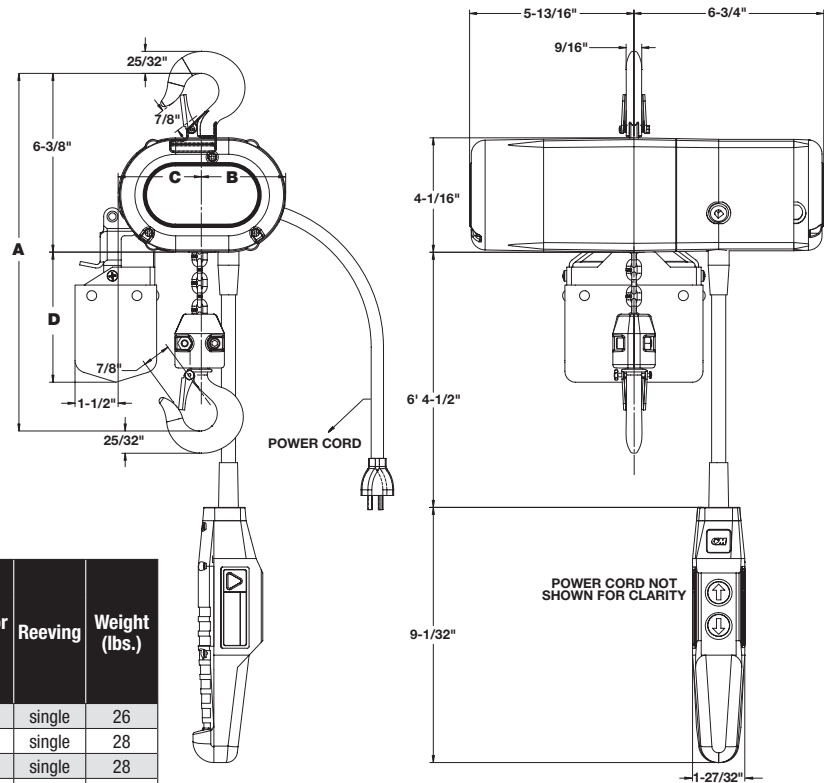

**SWIVEL HOOKS (OPTIONAL)**

Product Code	Description
10001130K	Shopstar/Prostar Swivel Latch-Type Hook Suspension
10001297K	Shopstar/Prostar Swivel Latchlok Hook Suspension



Phone (800) 888.0985 • Fax: (716) 689.5644 • www.cmworks.com